

# drew & cole<sup>®</sup>

SWITCHED ON LIVING

## CLEVERCHEF PRO<sup>™</sup>

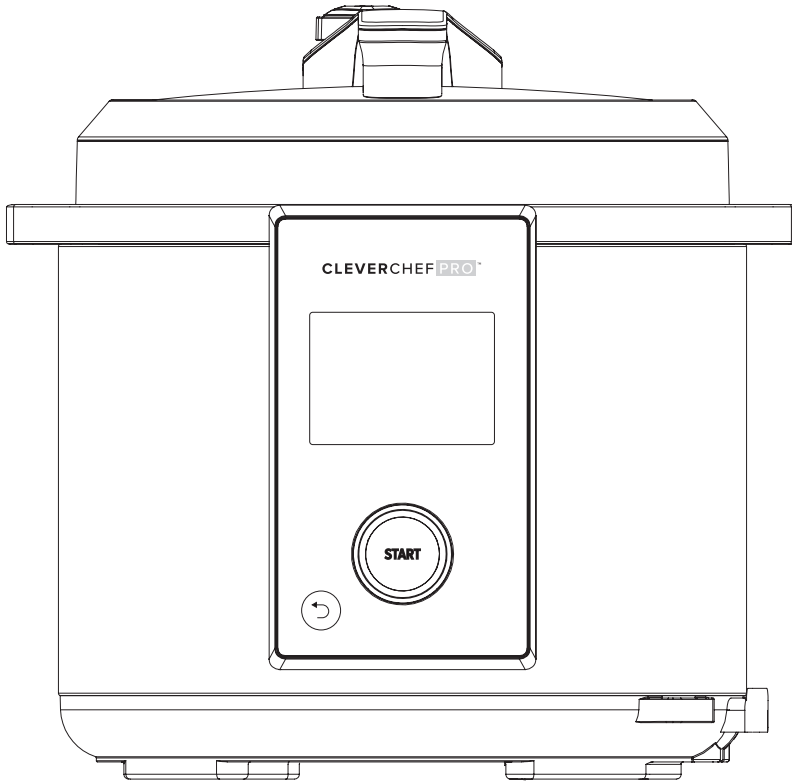

### User Manual

Register your product at  
[drewandcole.com/support](http://drewandcole.com/support)  
and visit us for...

FAQs



Videos



Recipes



Support



Join our community...



# Index

## Topic

---

Important Safety Information	04
Important safeguards	06
Safety features	11
Box contents	12
Assembling your pressure cooker	13
Before using for the first time	16
Adjusting the temperature	19
Adjusting the cooking time	19
Using the delay timer	20
Using the back/cancel function	20
Pressure cook function	21
Slow cook function	29
Multicook function	32
Steam function	35
Sauté function	39
Sous vide function	42
DIY function	46
Keep warm function	50
Useful tips	50
Care & cleaning	51
Troubleshooting	54
Spare parts	55
Specification	55

## Pressure Mode Correct Lid Placement

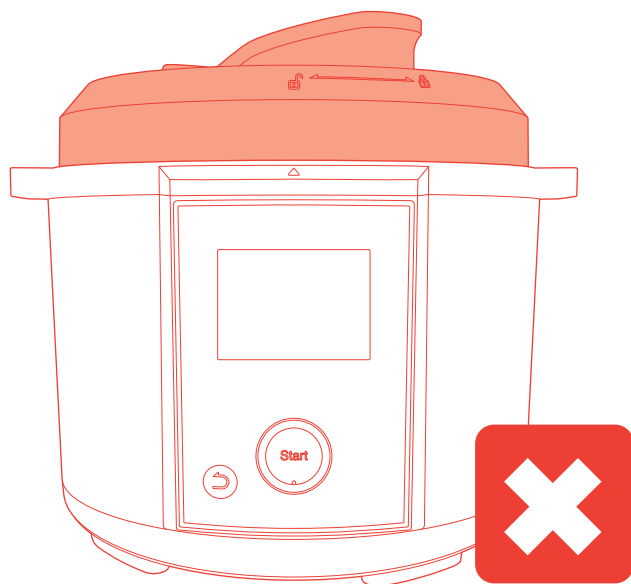
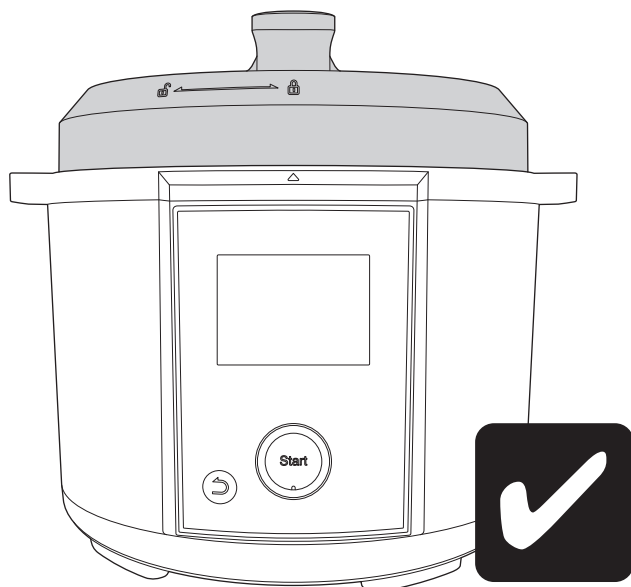

**NEVER FORCE THE APPLIANCE OPEN.**

**MAKE SURE THAT THE INSIDE PRESSURE HAS RETURNED TO NORMAL.**

IF YOU EXPERIENCE ANY PROBLEMS WITH THE APPLIANCE, SWITCH OFF AT THE PLUG AND CALL OUR CUSTOMER SUPPORT TEAM ON:

0344 800 0631 (UK)

0412 132 998 (Ireland)

EMAIL: [customer care@highstreettv.com](mailto:customer care@highstreettv.com)

# Important Safety Information

**BEFORE YOU GET STARTED, PLEASE READ THE FOLLOWING IMPORTANT SAFETY INFORMATION, ALONG WITH THE MANUAL ENCLOSED AND KEEP BOTH FOR FUTURE REFERENCE. WARNING YOU ARE WORKING WITH HOT LIQUIDS. YOU MUST READ THIS BEFORE USE.**

## Before cooking

- **ALWAYS** ensure the INNER POT is in place before cooking.
- Food with skins (e.g **sausages, chicken and fruit**) **MUST be pierced** before cooking. Not piercing the skin may result in the food expanding and may cause splashing of hot food after the lid is released.
- Do not overfill the inner pot, only fill the pot to 2/3rds of its capacity.

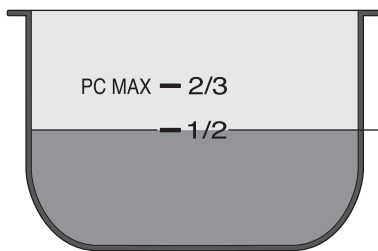

Beans, rice, pasta, pulses and porridge.



Everything else

- The lid must be closed fully before selecting a cooking function. Gently lower the lid and turn it anti-clockwise until it clicks into place.
- Ensure the pressure release valve is in the closed position (pressure cooking functions only), and check that it sits down correctly to seal the opening.

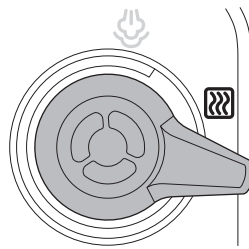
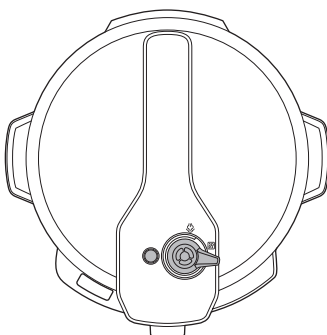

CLOSED

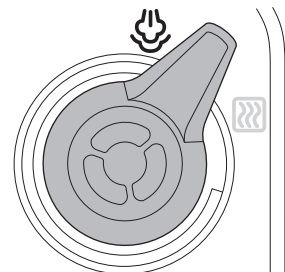

OPEN

# Important Safety Information (cont...)

## Pressure release methods

- When the programme is finished and you wish to commence pressure release press the  (back) button to cancel the Keep Warm function.
- When releasing the pressure release valve, always use tongs and please wear oven gloves to turn the pressure valve to the open position. This will protect against hot steam. The valve will lift up slightly and steam will release. The lid won't open until the steam has vented and pressure has released.
- When opening the lid food will be hot, please always wear oven gloves and an apron to protect against any splashing of the hot food.

## Quick release

### Recommended for:

Quick cooking recipes and steaming, including vegetables and seafood.

When the Keep Warm function has been cancelled, move the pressure release valve to the open position and only attempt to open lid when all steam has released and the pressure valve has dropped.

**Leave the pressure cooker to stand for 1 - 2 minutes.**

Press the lid release button and open the lid, if the lid does not open, wait a few more minutes and try again. Never try to force the lid off as a locked lid is a sign that the unit still has some pressure.

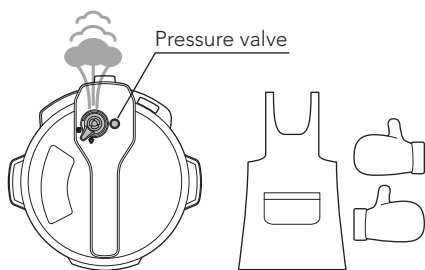

**Wait at least 1–2 mins.**

## Slow release

### Recommended for:

Food with skins (e.g sausages, chicken and fruit) and foods with large liquid volume or high starch content (such as porridge, soup, pasta, rice, fruit and grains, and also delicate foods such as meats and potato) can trap air and cause the food to foam and expand which may cause splashing of hot food after the lid is removed.

To avoid any splashing, after you have **cancelled the Keep Warm function** leave the pressure release valve in the closed position **and allow pressure to release naturally. This can take 15 minutes or more.** Recipe dependant. When the pressure valve has dropped, move the pressure release valve to open to ensure all the pressure is released.

Press the lid release button and open the lid, if the lid does not open, wait a few more minutes and try again. Never try to force the lid off as a locked lid is a sign that the unit still has some pressure.

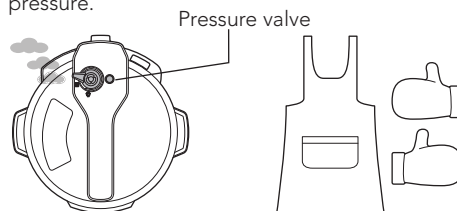

**Wait at least 15 mins.**

**For both methods, give the cooker a few gentle shakes** while holding the base unit handles to release any residual steam before opening the lid. There could still be steam held under the food that has not yet broken the surface. Without gentle shaking, this steam could come to the surface even several seconds after the lid has been removed.

**NEVER FORCE OPEN THE LID**

# Important Safeguards

**When using electrical appliances, basic safety precautions should always be followed including the following:**

- Read all instructions.
- Read and follow all instructions carefully.
- KEEP THESE INSTRUCTION
- This user's manual is also available in PDF format, please contact the Customer Services Team if you wish to have one.
- This appliance shall not be used by children. Keep the appliance and its cord out of reach of children.
- The appliance is not intended to be operated by means of an external timer or a separate remote-control system.
- The appliance may be used by persons with reduced physical, sensory or mental capabilities, or lack of experience or knowledge, if they have been given supervision or instruction concerning the use of the appliance. Children must be supervised to ensure they do not play with the appliance or any parts of the appliance or the packaging.
- Children shall not play with the appliance.
- To protect against electric shock do not immerse or rinse cords or plug in water or other liquid.
- Do not operate any appliance with a damaged cord or plug or after the appliance malfunctions or has been damaged in any manner.

## Important Safeguards (cont...)

Return appliance to the nearest authorised service facility for examination, repair or adjustment.

- Always check the pressure release devices for clogs before use
- Do not open the pressure cooker until the unit has cooled and all internal pressure has been released. If the unit is difficult to open, this indicates that the cooker is still pressurised – do not force it open. Any pressure in the cooker can be hazardous. Please read these instructions.
- **NEVER FORCE OPEN the pressure cooker. If you need to open the pressure cooker press the ↶ (back) button and using tongs or a kitchen tool carefully**

**rotate the pressure valve to the OPEN position to fully release the building pressure inside the cooker.**

**Leave until the unit & contents have cooled down fully. Make sure that all the steam has dissipated from the cooker. Carefully turn the handle clockwise to open. Always open the lid away from you to avoid skin contact with any remaining heat or steam.**

- This appliance is intended to be used in household and similar applications such as:
  - staff kitchen areas in shops, offices and other working environments;
  - farm houses;
  - by clients in hotels, motels and other

## Important Safeguards (cont...)

residential type environments;

– bed and breakfast type environments.

- The heating element surface is subject to residual heat after use, please pay attention to it.
- **AVOID SPILLAGE ON THE CONNECTOR.**
- Do not let children near the pressure cooker when in use.
- Do not put the pressure cooker into a heated oven.
- Move the pressure cooker under pressure with the greatest care. Do not touch hot surfaces. Use the handles and knobs. If necessary, use protection.
- Do not use the pressure cooker for a purpose other than the one for which it is intended.
- This appliance cooks under pressure, Scalds may result from inappropriate use of the pressure cooker. Make sure that the cooker is properly closed before applying heat, see 'Instructions for use'.
- Never force open the pressure cooker. Do not open before making sure that its internal pressure has completely dropped, see 'Instructions for use'.
- Never use your pressure cooker without adding water, this would seriously damage it.
- Do not fill the cooker beyond 2/3 of its capacity. When cooking foodstuffs which expand during cooking, such as rice or dehydrated vegetables, do not fill the cooker to more than half of its capacity.
- Use the appropriate heat source(s) according to the instructions of use.
- After cooking meat with a skin (e.g. ox tongue) which may swell under the effect of pressure, do not prick the meat while the skin is swollen; you might be scalded.
- When cooking doughy food, gently shake the cooker before opening the lid to avoid food ejection.
- Before each use, check that the valves are not obstructed, see 'Instructions for use'.
- Never use the pressure cooker in its pressurized mode for deep or shallow frying of food.
- Do not tamper with any of the safety systems beyond the maintenance instructions specified in the instructions for use.
- Only use manufacturer's spare parts in accordance with the relevant model. In particular, use a body and a lid from the same manufacturer indicated as being compatible.
- Unplug from outlet when not in use and before cleaning. Allow to cool before putting on or taking off parts.



## Important Safeguards (cont...)

- Do not touch hot surfaces. Use handles or knobs.
- Do not use any attachments or utensils that were not recommended or supplied by the manufacturer. The use of attachments not recommended for use by the manufacturer may cause serious hazardous situations including personal injury.
- Do not use outdoors.
- Do not let cord hang over edge of table or counter, or touch hot surfaces.
- **Do not place on or near a hot gas or electric burner, or in a heated oven.**
- Extreme caution must be used when moving an appliance containing hot oil or other hot liquids.
- Always attach plug to appliance first, then plug cord into the wall outlet. To disconnect, remove the plug from wall outlet.
- Do not use appliance for anything other than its intended use.
- **This appliance cooks under pressure. Improper use may result in scalding injury. Make certain that the unit is properly closed before operating. See instructions For Use.**
- **Never fill the unit above MAX line in the Inner Pot. When using foods that expand during cooking such as rice or dried beans, follow the recipe for "pressure cooking" those products, and as a rule of thumb, do not fill the unit above the "halfway" point. Overfilling may cause clogging, allowing excess pressure to develop.**
- **Be Aware that certain foods, such as apple-sauce, cranberries, pearl barley, oatmeal or other cereals, split peas, noodles, macaroni, rhubarb, and spaghetti, can foam, froth, sputter, and clog the pressure release device (steam vent). Recipes using these items must be followed carefully to avoid problems.**
- Do not use this pressure cooker for pressure frying with oil.
- This appliance has been designed for use with a 3 prong, grounded, 220-240V electrical outlet only. Do not use any other electrical outlet.
- **The pressure cooker generates extreme heat and steam in its operation. All necessary precautions must be taken to avoid fire, burns and other personal injury during its operation.**
- When in operation the pressure cooker requires sufficient air space on all sides including top and bottom. Never operate the unit near any flammable materials such as dish towels, paper towels, curtains, paper plates, etc.
- Always plug the electrical cord directly into the wall outlet. Never use this unit with an extension cord of any kind.
- Anyone who has not fully read and understood all operating and safety instructions contained in this manual is not qualified to operate or clean this appliance.
- If this unit falls or accidentally becomes immersed in water, unplug it from wall outlet immediately. Do not reach into the water!
- Do not operate this appliance on an unstable surface.

SAVE THESE INSTRUCTIONS- FOR HOUSEHOLD USE ONLY

## Important Safeguards (cont...)

- If this appliance begins to malfunction during use, immediately unplug the cord. Do not use or attempt to repair a malfunctioning appliance!
- **CAUTION: TO REDUCE RISK OF ELECTRIC SHOCK COOK ONLY IN THE REMOVABLE CONTAINER.**
- Do not immerse the housing or base in water.
- Before use, clean the bottom of the Inner Pot and the surface of the heater plate... insert the Inner Pot, turning it slightly clockwise and counter clockwise until you are sure it is sitting correctly on the heater plate. Failure to do so will prevent proper operation and may cause damage to the unit.
- **CAUTION HOT SURFACE. This appliance generates heat and escaping steam during use. Proper precautions must be taken to prevent the risk of personal injury, fires, and damage to property.**
- When in operation, never leave the appliance unattended.
- Be careful also about the risk of scalding from the steam coming out of the appliance when you open the lid. First open the lid very slightly to allow the steam to escape gently.
- If the silicon gasket or inner pot are damaged in any way. **DO NOT USE** and call customer services for a replacement.
- Make sure that the appliance is properly closed before bringing up to pressure (see Instructions for use).
- Do not use the appliance empty, without its inner pot or without liquid inside the inner pot. This could cause serious damage to the appliance.
- After cooking meat which has an outer layer of skin (such as Ox tongue, bacon joints, chicken etc.), which could swell (due to the effects of pressure), do not pierce the skin after cooking if it appears swollen: you could get burnt. Pierce it **BEFORE** cooking.
- When cooking food with a thick texture (chick peas, rhubarb, compotes, etc.), shake the appliance slightly before opening it to ensure that the food or cooking juices do not spurt out.
- Please be aware that quickly releasing the pressure after cooking is not suitable for food with a large liquid volume or high starch content (e.g. porridge, congee, sticky liquids, soup etc.). Food content may splatter out from the pressure release valve. Use natural release method instead - allow the cooker to cool down naturally until the pressure valve drops down. This may take between 15 and 20 minutes.
- **THE LID MUST BE CLOSED FULLY BEFORE SELECTING A PRESSURE FUNCTION.**
- **LET THE FOOD SETTLE FOR AT LEAST TWO MINUTES AFTER PRESSURE RELEASE PRESSURE VALVE HAS DROPPED.**
- **ALWAYS SHAKE THE UNIT SLIGHTLY AFTER THE PRESSURE VALVE HAS DROPPED BEFORE OPENING THE LID.**

## Important Safeguards (cont...)

### Need help? We're here for you.

Please contact our Customer Services Team on:

**Phone:** 0344 800 0631 (UK) / 0412 132 998 (Ireland)

**Email:** [customer-care@drewandcole.com](mailto:customer-care@drewandcole.com)

**Visit:** [drewandcole.com/support](http://drewandcole.com/support) for FAQ's

### Short Cord Instructions

- A short power-supply cord is provided to reduce the risk resulting from becoming entangled in or tripping over a longer cord. Do not use an extension cord with this product.

**NOTE:** This product must be grounded. If it should malfunction or break down, grounding provides a path of least resistance for electric current to reduce the risk of electric shock. This product is equipped with a cord having an equipment grounding conductor and a grounding plug.

The plug must be plugged into an appropriate outlet that is properly installed and grounded in accordance with all local codes and ordinances.

### Electric Power

- If the electrical circuit is overloaded with other appliances, your appliance may not operate properly. It should be operated on a dedicated electrical circuit

## Safety Features

- The pressure release valve will automatically exhaust and limit the pressure.
- If the pressure release valve fails the lid will release the pressure. In this case the pressure release valve is faulty and needs to be replaced.
- The cooker features a safety temperature cut out if the temperature rises too much, it will cut off and only start heating again when the temperature has returned to the normal temperature.
- If this function fails the pressure cooker will cut off, it will not re-start and needs to be replaced.
- The lid cannot be opened if the pressure inside is high.

# Box Contents

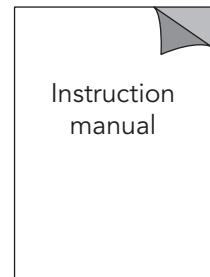
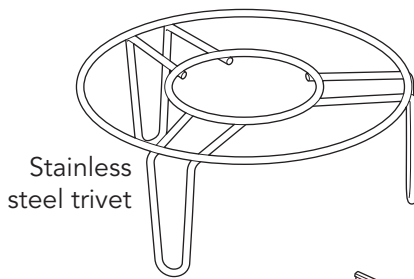
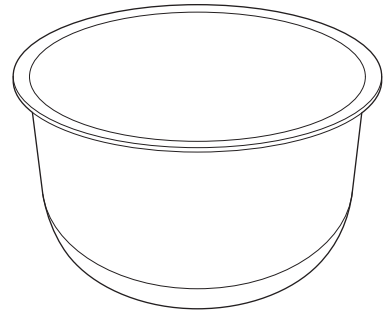
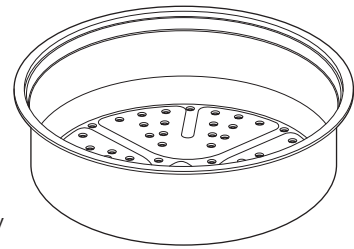
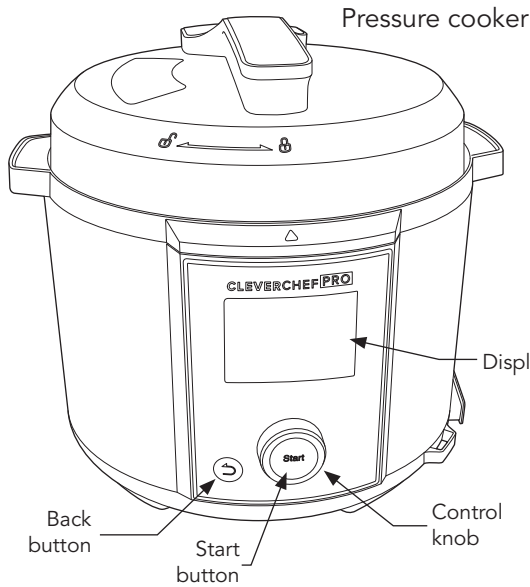

# Assembling Your Pressure Cooker

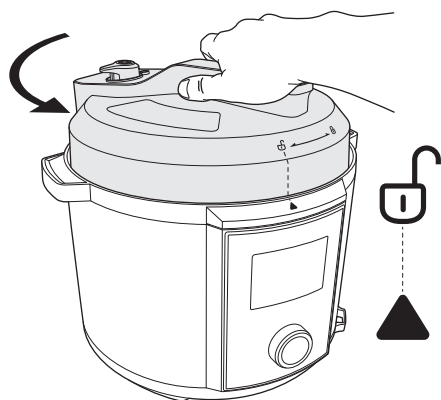

To open the lid, turn the handle anti-clockwise.

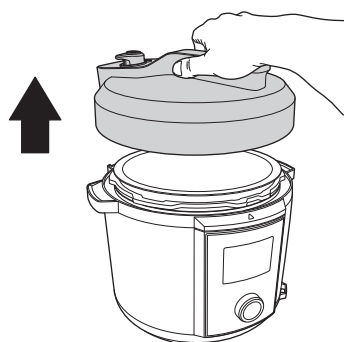

Now lift the lid off your pressure cooker.

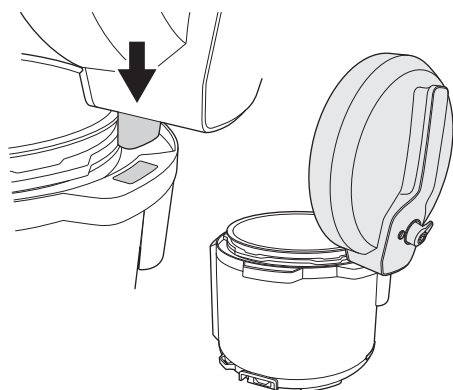

## Lid holder

You can slot the tab on the back of the lid into the slot on the back of the pressure cooker as shown in the diagram.

## Assembling Your Pressure Cooker (cont...)

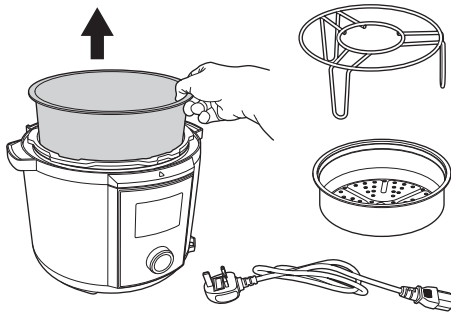

Remove the inner pot and all of its packaging.

Remove all of the items from inside the inner pot.

**Important:** Before using your pressure cooker for the first time you will have to wash the Inner pot, stainless steel trivet and stainless steel basket in warm soapy water, rinse then dry thoroughly. Never use metal scourers to clean the inner pot as this will damage the surface.

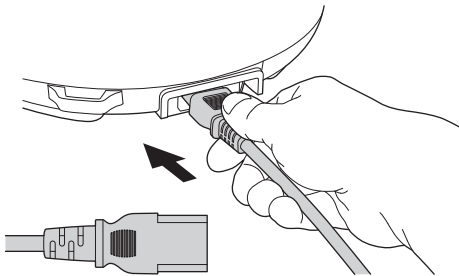

Slot the end of the power cord into the socket on the side of the pressure cooker as shown in the diagram.

Plug the other end of the power cable into a power socket and turn on the power at the socket if required.

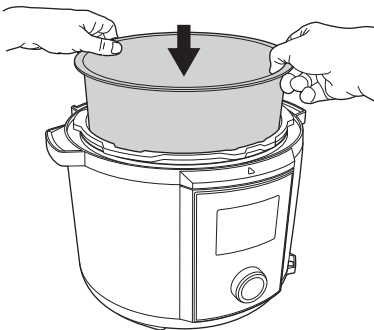

Place the inner pot into the outer body of the pressure cooker.

## Assembling Your Pressure Cooker (cont...)

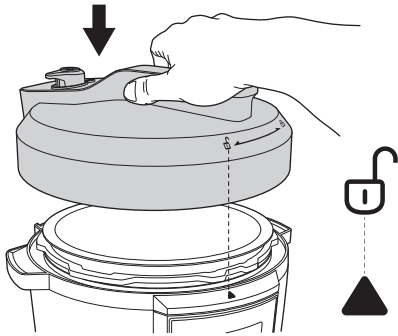

Place the lid back onto the pressure cooker.

Ensure the tab on the back of the lid slots into the channel on the back of the pressure cooker.

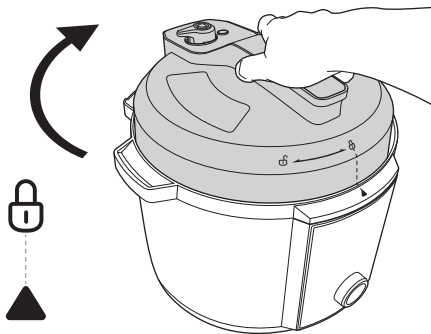

Turn the lid clockwise until it locks with a click.

Your pressure cooker is now ready for pressure cleaning, see page 18.

# Before Using For The First Time

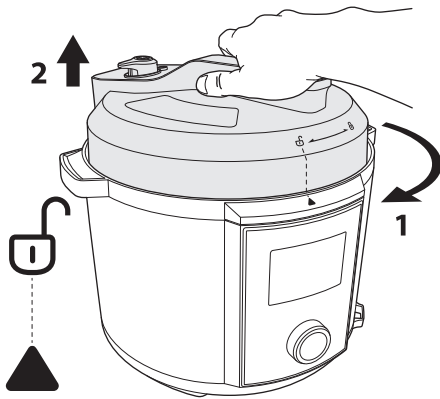



## How to Pressure Clean

Before using your Cleverchef Pro for the first time, pressure clean it by following the following instructions:

Remove the lid, as show on page 13 and pour 2 litres of water into the inner pot. Refit the lid and lock by turning clockwise, see page 15 for more information.

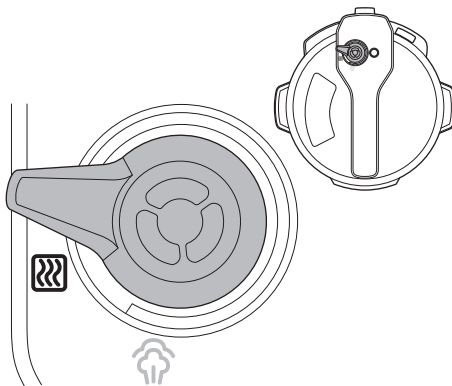
Turn the pressure cooker on at the mains socket if required.



Turn the pressure release valve to the CLOSED  position.

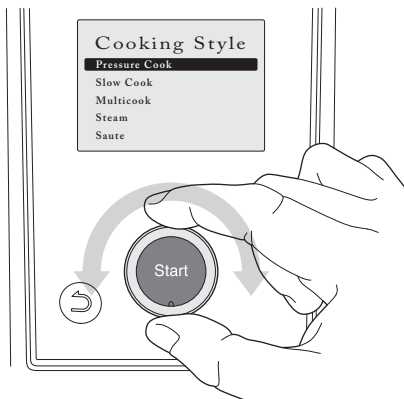

Select the **Pressure Cook** program by rotating the control knob.

Press the **Start** button in the middle of the control knob inwards to open the sub-menu.



## Before Using For The First Time (cont...)

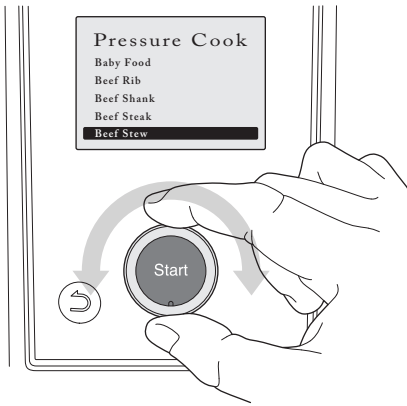

Select the **Beef Stew** program by rotating the control knob.

Press the **Start** button to open the cooking menu.

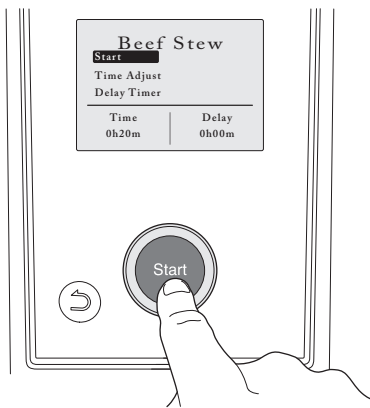

Press the **Start** button to begin the cooking process.

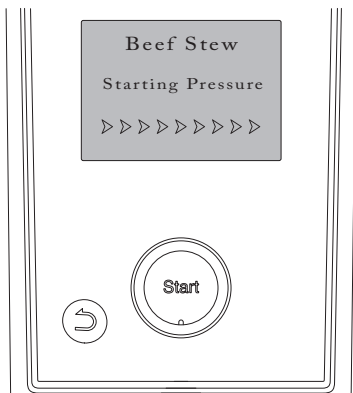

The display will turn yellow and the pressure cooker will now start the cooking process.

When the cooking process has finished you will hear a beep and the screen will turn yellow.

## Before Using For The First Time (cont...)

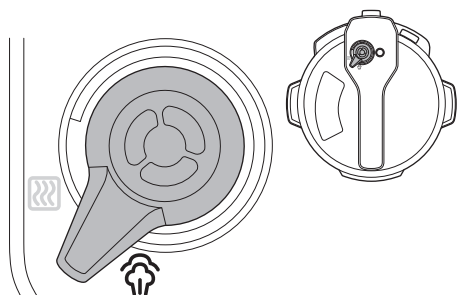

### Release pressure

You will now have to open the pressure release valve, to do this cover your hand with an oven glove or similar or better use a pair of tongs to turn the valve to the release  position.

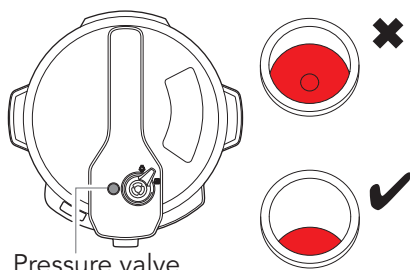

After steam has stopped coming out of the pressure release valve, check that the pressure valve has dropped before opening the pressure cooker's lid.

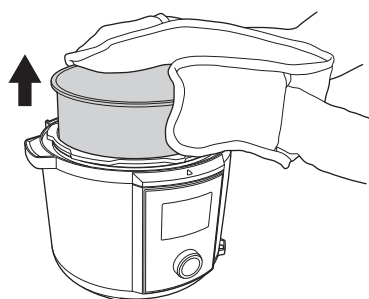

Remove the lid, as shown on page 13.

Remove and empty the inner pot using oven gloves or a heat proof cloth.

Your pressure cooker's inner valves and lid are now thoroughly cleaned.



Allow all of the components of the pressure cooker to cool then dry the inner pot, lid and the inside of the pressure cooker with a soft cloth.

Place the inner pot back into the pressure cooker and refit the lid.

Your pressure cooker is now ready for use.

## Adjusting The Temperature

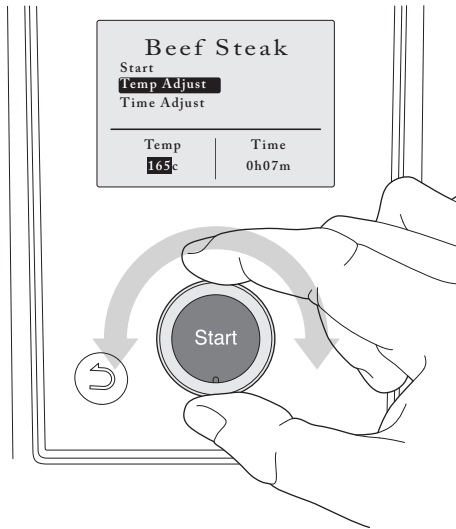

**Important:** You cannot adjust the temperature for the pressure, steam or keep warm cooking programs.

Select **Temp Adjust** by rotating the control knob then press the **Start** button.

The **Temp** section at the bottom of the screen will be highlighted. Rotate the control knob to adjust the temperature and press the **Start** button to set the new temperature.

## Adjusting The Cooking Time

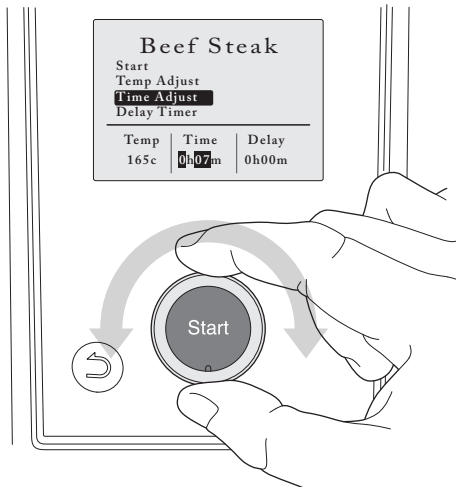

Select **Time Adjust** by rotating the control knob then press the **Start** button.

The **Time** section at the bottom of the screen will be highlighted. Rotate the control knob to adjust the temperature and press the **Start** button to set the new temperature.

## Using The Delay Timer

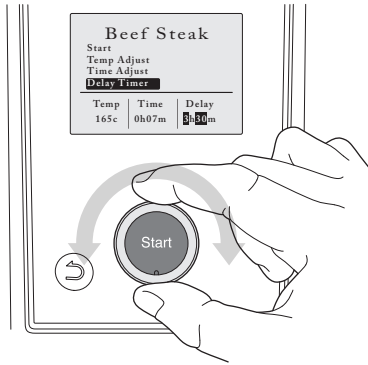

Use the control knob to select the **Delay Timer** setting and press the **Start** button to access.

Use the control knob to adjust the delay timer in 30 minute intervals to a maximum of 24 hours.

When you have the desired time press the **Start** button to confirm.

Use the control knob to scroll up to the **Start** setting then press the **Start** button.

The screen will show the countdown until the cooking process starts.

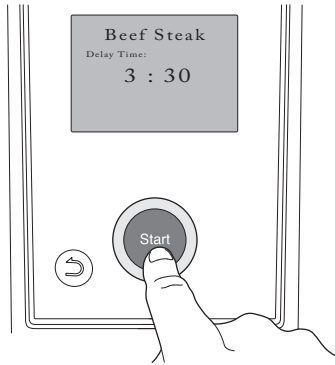

## Using The Back/Cancel Function

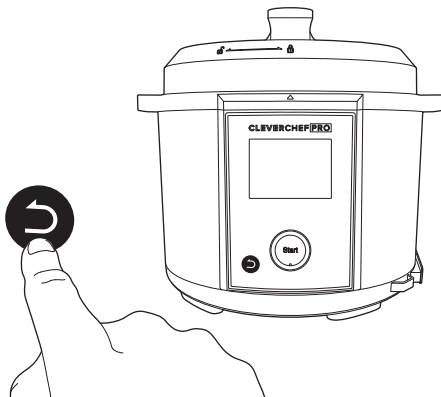

During the cooking process or when using the menus simply press the  button to go back one screen on the menu or to cancel your cooking process.

# Pressure Cook Function



**Important:** Ensure inside of the pressure cooker and the inner pot are clean and free from any food debris before starting.

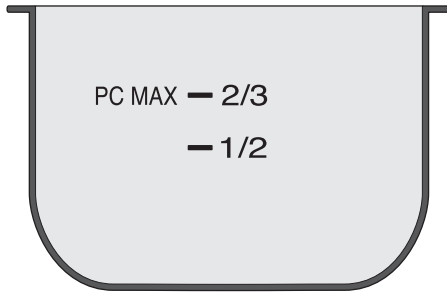

## Filling the inner pot

**NEVER** place food or liquid directly into the pressure cooker. Always use the inner pot to cook food in.

Remove the inner pot from your pressure cooker and fill with the ingredients required for the recipe.

Place the liquid in the inner pot.

**Important:** Do not fill the pot beyond 2/3rds of its capacity. The liquid and ingredients should be between the 2/3 and 1/2 marks on the inside of the inner pot.

**Important:** When cooking ingredients that expand during cooking, we recommend that you only fill the inner pot halfway between the 2/3 and 1/2 marks.



**CAUTION:** When using as a pressure cooker, always use liquid in the inner pan. The liquid should always come up to the 1/2 mark.

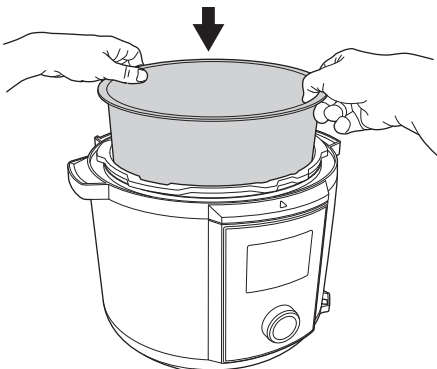

Place the inner pot into the pressure cooker.

Take care not to spill any liquid when placing the pot in the pressure cooker.

If you do clean up with a damp cloth

## Pressure Cook Function (cont...)

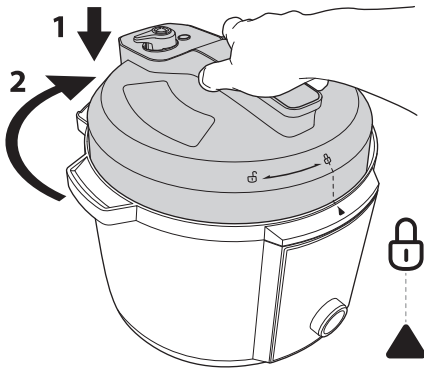

Fit the lid and close by turning it clockwise until it locks with a click.

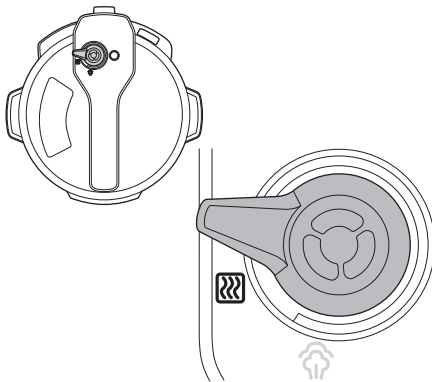

### Pressure release valve

To cook under pressure you **MUST** turn the pressure release valve to the closed position  as indicated on the case near the valve.

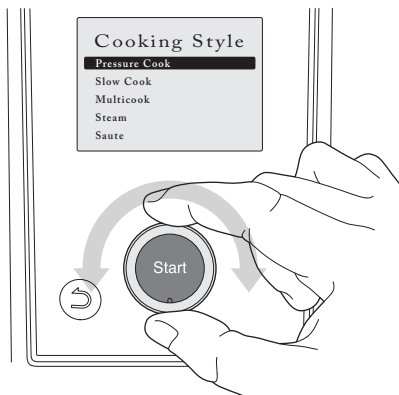

Select **Pressure Cook** from the cooking style menu by turning the control knob then press the **Start** button to open the next menu.

# Pressure Cook Function (cont...)

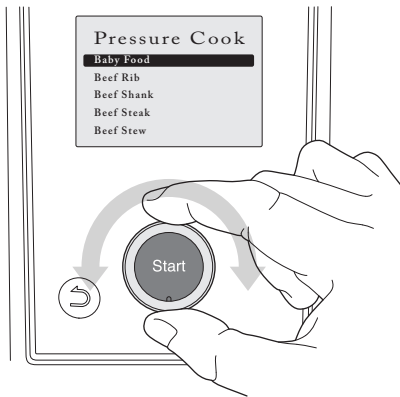

## Selecting a cooking program

Scroll through the preset cooking programs by turning the control knob clockwise to go down or anti-clockwise to go up to find the correct program for your ingredients and press the **Start** button.

See the lists on pages 24 and 25 for more information.

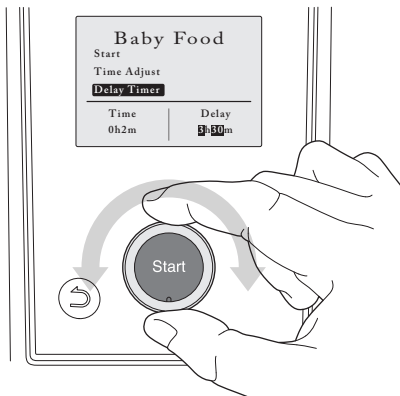

## Adjusting the cooking program

You can now adjust the cooking time or delay timer of the program if required using the control knob as shown on pages 19 & 20.

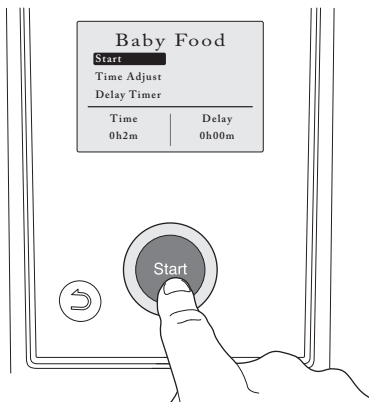

After you have made all of the changes you want, Use the control knob to highlight Start on the display then press the **Start** button to start the cooking process.

# Pressure Cook Program List

Program	Cooking time	Time adjust range	Temp adjust range	Delay time range	Keep warm default	Lid ON/OFF
Baby food	5 mins	1 to 60 mins	N/A	0 mins to 24 hrs	24 hrs	ON
Beef rib	50 mins	1 to 180 mins	N/A	0 mins to 24 hrs	24 hrs	ON
Beef shank	40 mins	1 to 60 mins	N/A	0 mins to 24 hrs	24 hrs	ON
Beef brisket	75 mins	1 to 90 mins	N/A	0 mins to 24 hrs	24 hrs	ON
Beef stew	20 mins	1 to 120 mins	N/A	0 mins to 24 hrs	24 hrs	ON
Broth	45 mins	1 to 60 mins	N/A	0 mins to 24 hrs	24 hrs	ON
Chicken breast	6 mins	1 to 60 mins	N/A	0 mins to 24 hrs	24 hrs	ON
Chicken leg	15 mins	1 to 60 mins	N/A	0 mins to 24 hrs	24 hrs	ON
Chicken thigh	12 mins	1 to 60 mins	N/A	0 mins to 24 hrs	24 hrs	ON
Chicken whole	25 mins	1 to 60 mins	N/A	0 mins to 24 hrs	24 hrs	ON
Chilli beef	20 mins	1 to 60 mins	N/A	0 mins to 24 hrs	24 hrs	ON
Chilli veg	5 mins	1 to 60 mins	N/A	0 mins to 24 hrs	24 hrs	ON
Curry beef	20 mins	1 to 60 mins	N/A	0 mins to 24 hrs	24 hrs	ON
Curry chicken	15 mins	1 to 60 mins	N/A	0 mins to 24 hrs	24 hrs	ON
Curry veg	5 mins	1 to 60 mins	N/A	0 mins to 24 hrs	24 hrs	ON
Fish	2 mins	1 to 60 mins	N/A	0 mins to 24 hrs	24 hrs	ON
Lamb chop	8 mins	1 to 60 mins	N/A	0 mins to 24 hrs	24 hrs	ON
Lamb leg	30 mins	1 to 60 mins	N/A	0 mins to 24 hrs	24 hrs	ON
Lamb shank	30 mins	1 to 60 mins	N/A	0 mins to 24 hrs	24 hrs	ON
Multigrain	11 mins	1 to 60 mins	N/A	0 mins to 24 hrs	24 hrs	ON



# Pressure Cook Program List (cont...)

Program	Cooking time	Time adjust range	Temp adjust range	Delay time range	Keep warm default	Lid ON/OFF
Pork loin	8 mins	1 to 60 mins	N/A	0 mins to 24 hrs	24 hrs	ON
Pork pulled	75 mins	1 to 75 mins	N/A	0 mins to 24 hrs	24 hrs	ON
Pork joint	45 mins	1 to 60 mins	N/A	0 mins to 24 hrs	24 hrs	ON
Pork ribs	20 mins	1 to 60 mins	N/A	0 mins to 24 hrs	24 hrs	ON
Rice basmati	12 mins	1 to 60 mins	N/A	0 mins to 24 hrs	24 hrs	ON
Rice brown	20 mins	1 to 60 mins	N/A	0 mins to 24 hrs	24 hrs	ON
Rice long grain	12 mins	1 to 60 mins	N/A	0 mins to 24 hrs	24 hrs	ON
Rice white	12 mins	1 to 60 mins	N/A	0 mins to 24 hrs	24 hrs	ON
Risotto	10 mins	1 to 60 mins	N/A	0 mins to 24 hrs	24 hrs	ON
Soup veg	10 mins	1 to 120 mins	N/A	0 mins to 24 hrs	24 hrs	ON
Soup meat	30 mins	1 to 120 mins	N/A	0 mins to 24 hrs	24 hrs	ON
Sterilize	15 mins	1 to 60 mins	N/A	0 mins to 24 hrs	24 hrs	ON
Veg asparagus	1 mins	1 to 60 mins	N/A	0 mins to 24 hrs	24 hrs	ON
Veg beans	25 mins	1 to 60 mins	N/A	0 mins to 24 hrs	24 hrs	ON
Veg broccoli	1 mins	1 to 60 mins	N/A	0 mins to 24 hrs	24 hrs	ON
Veg cauliflower	1 mins	1 to 60 mins	N/A	0 mins to 24 hrs	24 hrs	ON
Veg mix fresh	1 mins	1 to 60 mins	N/A	0 mins to 24 hrs	24 hrs	ON
Veg mix frozen	1 mins	1 to 60 mins	N/A	0 mins to 24 hrs	24 hrs	ON
Veg new potato	7 mins	1 to 60 mins	N/A	0 mins to 24 hrs	24 hrs	ON
Veg potato	12 mins	1 to 60 mins	N/A	0 mins to 24 hrs	24 hrs	ON
Veg corn cob	1 mins	1 to 60 mins	N/A	0 mins to 24 hrs	24 hrs	ON

## Pressure Cook Function (cont...)



After pressing the **Start** button the yellow pressure build screen will be shown.

If you have used the delay feature the delay countdown will be shown on the display. After the countdown has ended the cooking process will begin.



Before the cooking process can begin the pressure cooker will need to heat up to create the pressure level in the cooker.

Once the correct cooking pressure has been reached, the countdown will start.

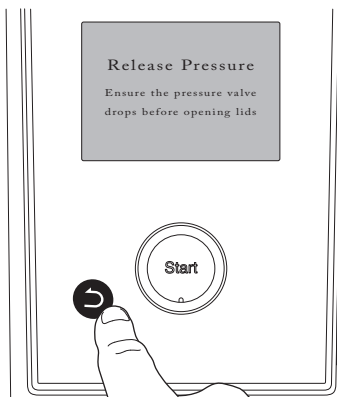

After the cooking process has finished, the pressure cooker will keep several times and automatically go into the pressure release screen. After a period of time the pressure cooker will enter the keep warm mode.

Press the  (back) button to exit the keep warm function.

# Pressure Cook Function (cont...)



**CAUTION:** Before attempting to open the pressure cookers lid you will need to release the steam. Follow the instructions below and take great care as steam can give you serious burns.

**SEE BELOW FOR PRESSURE RELEASE METHOD TO BE USED.**

## Pressure release methods

- When the programme is finished and you wish to commence pressure release press the  (back) button to cancel the Keep Warm function.
- When releasing the pressure release valve, always use tongs and please wear oven gloves to turn the pressure valve to the open position. This will protect against hot steam. The valve will lift up slightly and steam will release. The lid won't open until the steam has vented and pressure has released.
- When opening the lid food will be hot, please always wear oven gloves and an apron to protect against any splashing of the hot food.

## Quick release

### Recommended for:

Quick cooking recipes and steaming, including vegetables and seafood.

When the Keep Warm function has been cancelled, move the pressure release valve to the open position and only attempt to open lid when all steam has released and the pressure valve has dropped.

**Leave the pressure cooker to stand for 1 - 2 minutes.**

Press the lid release button and open the lid, if the lid does not open, wait a few more minutes and try again. Never try to force the lid off as a locked lid is a sign that the unit still has some pressure.

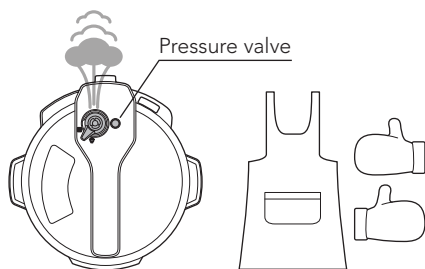

**Wait at least 1–2 mins.**

## Slow release

### Recommended for:

Food with skins (e.g sausages, chicken and fruit) and foods with large liquid volume or high starch content (such as porridge, soup, pasta, rice, fruit and grains, and also delicate foods such as meats and potato) can trap air and cause the food to foam and expand which may cause splashing of hot food after the lid is removed.

To avoid any splashing, after you have **cancelled the Keep Warm function** leave the pressure release valve in the closed position **and allow pressure to release naturally. This can take 15 minutes or more.** Recipe dependant.. When the pressure valve has dropped, move the pressure release valve to open to ensure all the pressure is released.

Press the lid release button and open the lid, if the lid does not open, wait a few more minutes and try again. Never try to force the lid off as a locked lid is a sign that the unit still has some pressure.

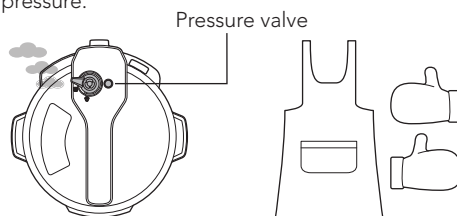

**Wait at least 15 mins.**

# Pressure Cook Function (cont...)

For both methods, give the cooker a few gentle shakes while holding the base unit handles to release any residual steam before opening the lid. There could still be steam held under the food that has not yet broken the surface. Without gentle shaking, this steam could come to the surface even several seconds after the lid has been removed.

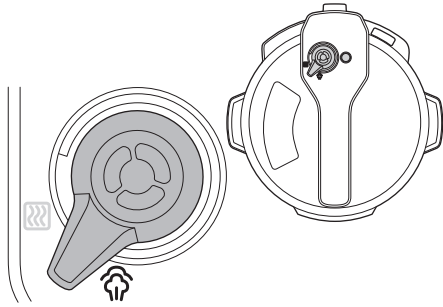

## Releasing the steam

You will now have to open the pressure release valve, to do this cover your hand with an oven glove or something similar. Alternatively a better option is to use a pair of tongs to turn the valve to one of the release  settings.

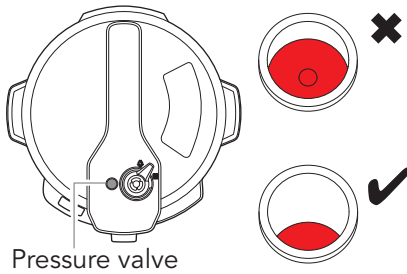

After steam has stopped coming out of the pressure release valve, check that the pressure valve has dropped before opening the pressure cooker's lid.

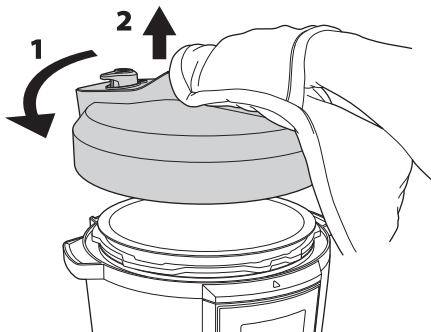

You can now open the pressure cooker's lid by turning the lid anti-clockwise (1) then lifting off upwards (2). Remove the inner pot using a heat proof cloth or oven glove. After using your pressure cooker please clean it by following the Care & Maintenance section of these instructions. **NEVER TOUCH THE PRESSURE VALVE DURING COOKING.**



**CAUTION:** After cooking the lid, inner casing, inner pot and food will be very hot and should be handled with caution.

# Slow Cook Function



**Important:** The Slow Cook program does not use steam pressure to cook the ingredients so the pressure release valve **must be set in the open position**.

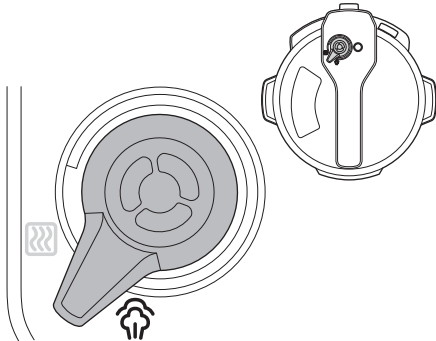

## Pressure release valve

You **MUST** turn the pressure release valve to the open position  as indicated on the valve.



Select **Slow Cook** from the cooking style menu by turning the control knob then press the **Start** button.

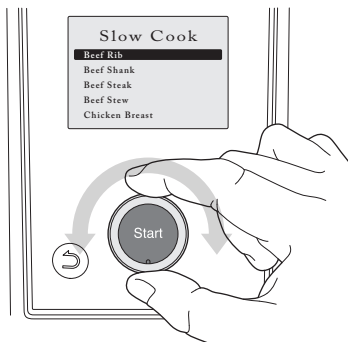

## Selecting a cooking program

Scroll through the preset cooking programs by turning the control knob clockwise to go down or anti-clockwise to go up to find the correct program for your ingredients and press the **Start** button.

See the lists on page 30 for more information.

# Slow Cook Program List

Program	Cooking time	Time adjust range	Temperature	Temp adjust range	Delay time range	Keep warm default	Lid ON/OFF
Beef rib	180 mins	60 to 240 mins	95°C	80 to 95°C	0 mins to 24 hrs	24 hrs	ON
Beef shank	180 mins	60 to 240 mins	95°C	80 to 95°C	0 mins to 24 hrs	24 hrs	ON
Beef steak	180 mins	60 to 240 mins	95°C	80 to 95°C	0 mins to 24 hrs	24 hrs	ON
Beef stew	180 mins	60 to 240 mins	95°C	80 to 95°C	0 mins to 24 hrs	24 hrs	ON
Chicken breast	180 mins	60 to 240 mins	95°C	80 to 95°C	0 mins to 24 hrs	24 hrs	ON
Chicken leg	180 mins	60 to 240 mins	95°C	80 to 95°C	0 mins to 24 hrs	24 hrs	ON
Chicken thigh	180 mins	60 to 240 mins	95°C	80 to 95°C	0 mins to 24 hrs	24 hrs	ON
Chili beef	180 mins	60 to 240 mins	95°C	80 to 95°C	0 mins to 24 hrs	24 hrs	ON
Chili veg	120 mins	60 to 180 mins	95°C	80 to 95°C	0 mins to 24 hrs	24 hrs	ON
Curry beef	180 mins	60 to 240 mins	95°C	80 to 95°C	0 mins to 24 hrs	24 hrs	ON
Curry chicken	180 mins	60 to 240 mins	95°C	80 to 95°C	0 mins to 24 hrs	24 hrs	ON
Curry veg	120 mins	60 to 180 mins	95°C	80 to 95°C	0 mins to 24 hrs	24 hrs	ON
Lamb chop	180 mins	60 to 240 mins	95°C	80 to 95°C	0 mins to 24 hrs	24 hrs	ON
Lamb leg	240 mins	60 to 240 mins	95°C	80 to 95°C	0 mins to 24 hrs	24 hrs	ON
Lamb shank	180 mins	60 to 240 mins	95°C	80 to 95°C	0 mins to 24 hrs	24 hrs	ON
Pork loin	180 mins	60 to 240 mins	95°C	80 to 95°C	0 mins to 24 hrs	24 hrs	ON
Pork chop	180 mins	60 to 240 mins	95°C	80 to 95°C	0 mins to 24 hrs	24 hrs	ON
Pork joint	240 mins	60 to 240 mins	95°C	80 to 95°C	0 mins to 24 hrs	24 hrs	ON
Pork ribs	180 mins	60 to 240 mins	95°C	80 to 95°C	0 mins to 24 hrs	24 hrs	ON

## Slow Cook Function (cont...)

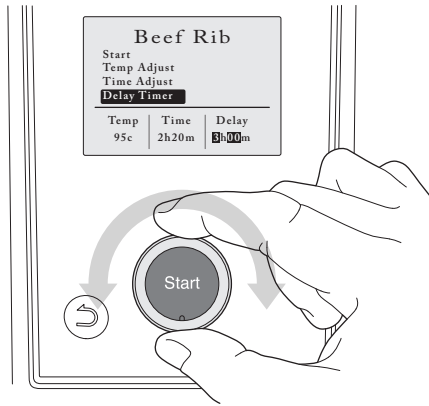

### Adjusting the cooking program

You can now adjust the temperature, cooking time or delay timer of the program if required using the control knob as shown on pages 19 and 20.



After you have made all of the changes you want, Use the control knob to highlight Start on the display then press the **Start** button to start the cooking process.

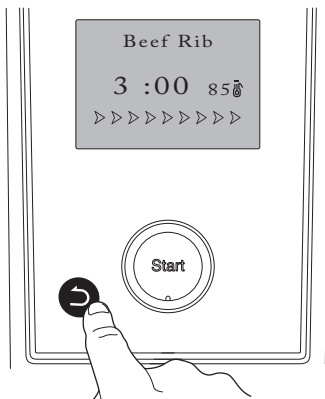

After pressing the **Start** button the orange cooking screen will be shown.

After the cooking program has finished you will hear a several beeps and the pressure cooker will automatically go into the keep warm mode for a maximum of 24 hours.

Press the  (back) button to exit the keep warm function.

# Multicook Function



**Important:** The Multicook program does not use steam pressure to cook the ingredients so the pressure release valve **must be set in the open position.**



## Pressure release valve

You **MUST** turn the pressure release valve to the open position  as indicated on the valve.



Select Multicook from the menu by rotating the control knob then press the start button.

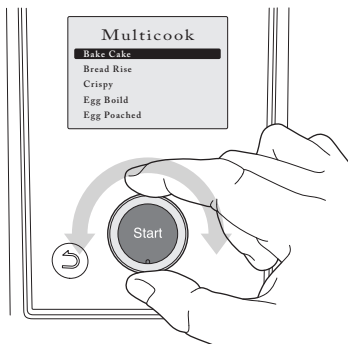

## Selecting a cooking program

Scroll through the preset cooking programs by turning the control knob clockwise to go down or anti-clockwise to go up to find the correct program for your ingredients and press the **Start** button.

See the lists on page 33 for more information on the cooking programs.



## Multicook Function (cont...)

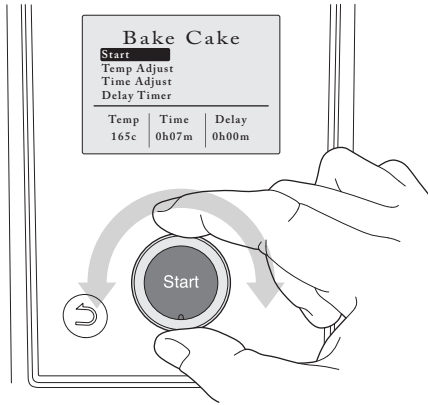

### Adjusting the cooking program

You can now adjust the temperature, cooking time or delay timer of the program if required using the control knob as shown on pages 19 and 20.

## Multicook Program List

Program	Cooking time	Time adjust range	Temperature	Temp adjust range	Delay time range	Keep warm default	Lid ON/OFF
Bake cake	40 mins	1 to 60 mins	145°C	100 to 165°C	0 mins to 24 hrs	24 hrs	ON
Bread rise	30 mins	1 to 60 mins	40°C	38 to 42°C	0 mins to 24 hrs	N/A	ON
Crispy	45 mins	1 to 60 mins	165°C	100 to 165°C	0 mins to 24 hrs	24 hrs	ON
Egg boiled	6 mins	1 to 60 mins	100°C	80 to 100°C	0 mins to 24 hrs	24 hrs	ON
Egg poached	4 mins	1 to 60 mins	80°C	80 to 100°C	0 mins to 24 hrs	24 hrs	ON
Pasta	8 mins	1 to 60 mins	100°C	80 to 140°C	0 mins to 24 hrs	24 hrs	ON
Yoghurt	8 hours	6 to 10 hrs	38°C	38 to 42°C	0 mins to 24 hrs	N/A	ON

## Multicook Function (cont...)



After you have made all of the changes you want, Use the control knob to highlight Start on the display then press the **Start** button to start the cooking process.

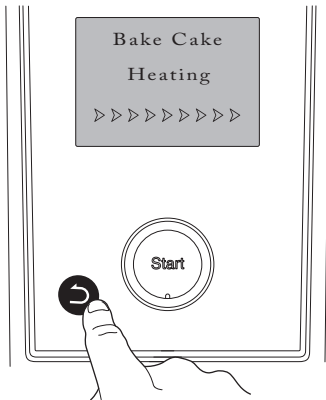

After pressing the **Start** button the yellow heating screen will be shown. Once the pressure cooker reaches temperature the cooking program will begin.

After the cooking program has finished you will hear a several beeps and the pressure cooker will automatically go into the keep warm mode for a maximum of 24 hours.

Press the ↶ (back) button to exit the keep warm function.

**Note:** The Bread Rise and Yogurt programs do not use the keep warm function.

# Steam Function



**Important:** The Steam program does not use steam pressure to cook the ingredients so the pressure release valve **must be set in the open position.**

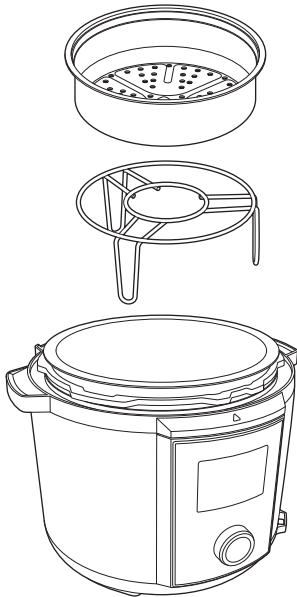

If you want to use your pressure cooker as a steamer you will have to place the stainless steel trivet into the bottom of the inner pot.

Place water or stock up to the 1/2 fill line on the inner pot.

You can cook large items such as fish, meat or larger vegetables directly on the stainless steel trivet.

For smaller items, you can place them into the stainless steel basket then place the basket on top of the trivet.

**IMPORTANT:** Never place the basket directly on the bottom of the inner pot when steaming.

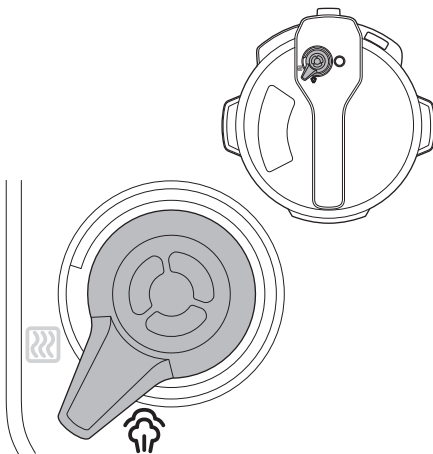

Refit the pressure cookers lid and close it.

Ensure the pressure release valve is in the  position.

## Steam Function (cont...)



Select Steam from the menu by rotating the control knob then press the start button.

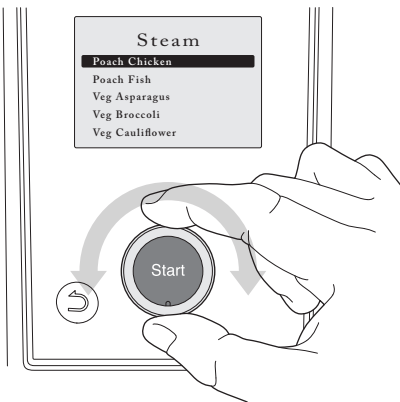

### Selecting a cooking program

Scroll through the preset cooking programs by turning the control knob clockwise to go down or anti-clockwise to go up to find the correct program for your ingredients and press the **Start** button.

See the lists on page 37 for more information.

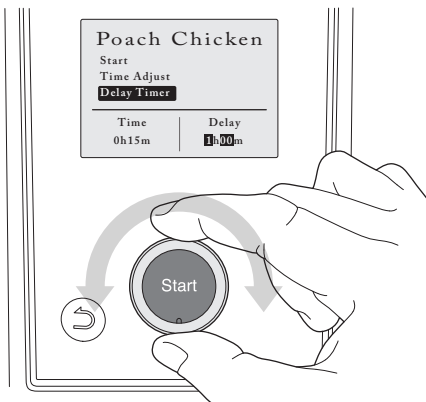

### Adjusting the cooking program

You can now adjust the cooking time or delay timer of the program if required using the control knob as shown on pages 19 and 20.

# Steam Program List

Program	Cooking time	Time adjust range	Temperature	Temp adjust range	Delay time range	Keep warm default	Lid ON/OFF
Poach chicken	15 mins	1 to 60 mins	95°C	N/A	0 mins to 24 hrs	24 hrs	ON
Poach fish	5 mins	1 to 60 mins	95°C	N/A	0 mins to 24 hrs	24 hrs	ON
Veg asparagus	5 mins	1 to 60 mins	95°C	N/A	0 mins to 24 hrs	24 hrs	ON
Veg broccoli	6 mins	1 to 60 mins	95°C	N/A	0 mins to 24 hrs	24 hrs	ON
Veg cauliflower	7 mins	1 to 60 mins	95°C	N/A	0 mins to 24 hrs	24 hrs	ON
Veg mix fresh	6 mins	1 to 60 mins	95°C	N/A	0 mins to 24 hrs	24 hrs	ON
Veg mix frozen	7 mins	1 to 60 mins	95°C	N/A	0 mins to 24 hrs	24 hrs	ON
Veg new potato	20 mins	1 to 60 mins	95°C	N/A	0 mins to 24 hrs	24 hrs	ON
Veg potato	30 mins	1 to 60 mins	95°C	N/A	0 mins to 24 hrs	24 hrs	ON

## Steam Function (cont...)

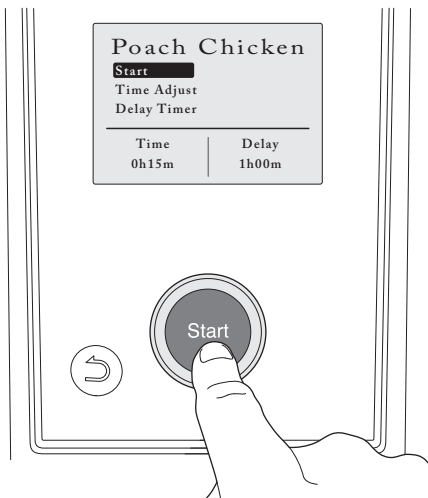

After you have made all of the changes you want, Use the control knob to highlight Start on the display then press the **Start** button to start the cooking process.

## Steam Function (cont...)

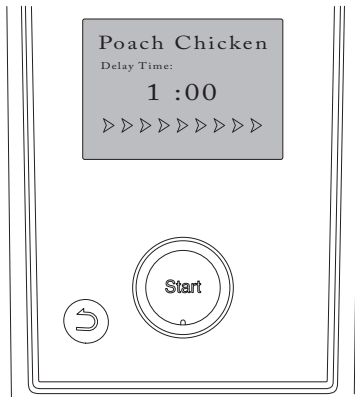

After pressing the Start button the orange cooking screen will be shown.

If you have used the delay setting the cooking process will start after the delay countdown has finished.



After the cooking program has finished you will hear a several beeps and the pressure cooker will automatically go into the keep warm mode for a maximum of 24 hours.



Press the  (back) button to exit the keep warm function.

# Sauté Function



**WARNING:** The lid **MUST** be removed from the pressure cooker when using the Sauté function.

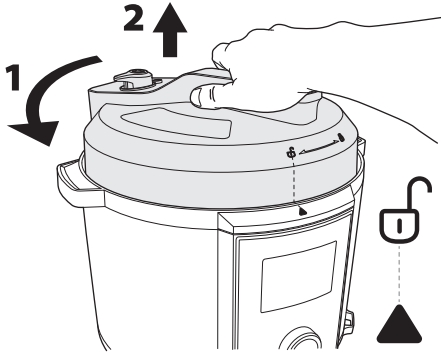

Remove the lid by turning the handle anti-clockwise (1).

Lift the lid off the pressure cooker (2).

Plug your pressure cooker in and turn the power on at the socket if required.

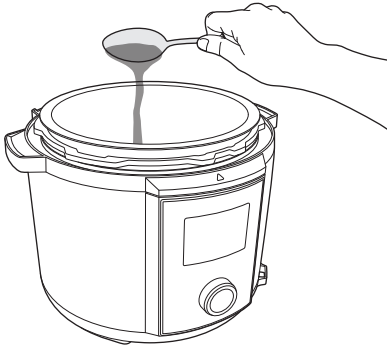

Place a small amount of oil (check recipe) in the bottom of the inner pot.



Select the **Sauté** program by rotating the control knob then press the **Start** button.

## Sauté Function (cont...)

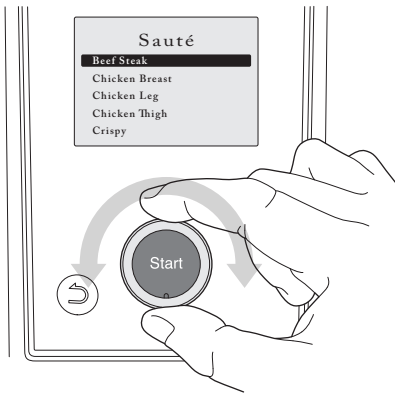

Select the appropriate cooking program by rotating the control knob and then press the **Start** button to open the cooking program.

**Note:** The list of the available cooking programs is shown below as well as the adjustment ranges.

## Sauté Program List

Program	Cooking time	Time adjust range	Temperature	Temp adjust range	Lid ON/OFF
Beef steak	7 mins	1 to 60 mins	165°C	100 to 165°C	OFF
Chicken breast	10 mins	1 to 60 mins	165°C	100 to 165°C	OFF
Chicken leg	15 mins	1 to 60 mins	165°C	100 to 165°C	OFF
Chicken thigh	15 mins	1 to 60 mins	165°C	100 to 165°C	OFF
Crispy	45 mins	1 to 60 mins	165°C	100 to 165°C	OFF
Lamb chop	8 mins	1 to 60 mins	165°C	100 to 165°C	OFF
Veg asparagus	8 mins	1 to 60 mins	165°C	100 to 165°C	OFF
Veg broccoli	8 mins	1 to 60 mins	165°C	100 to 165°C	OFF
Veg cauliflower	15 mins	1 to 60 mins	165°C	100 to 165°C	OFF
Veg new potato	15 mins	1 to 60 mins	165°C	100 to 165°C	OFF



## Sauté Function (cont...)

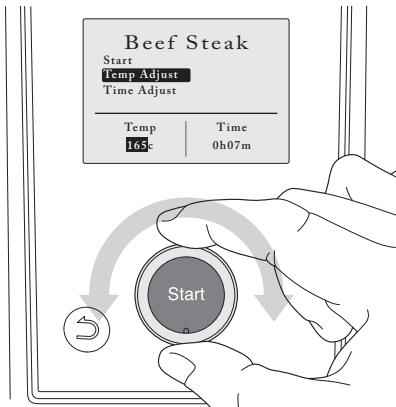

You can now adjust the temperature, cooking Temp or Time of the program if you want to using the control knob as shown on page 19 and 20.

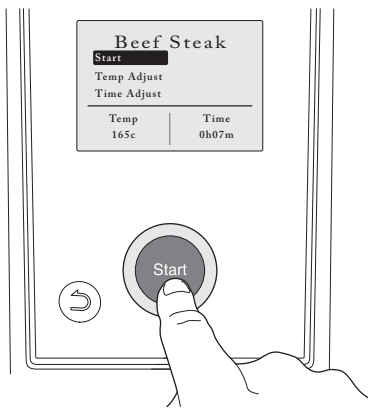

Select **Start** from the menu by rotating the control knob.

Press the **Start** button to begin the cooking process.

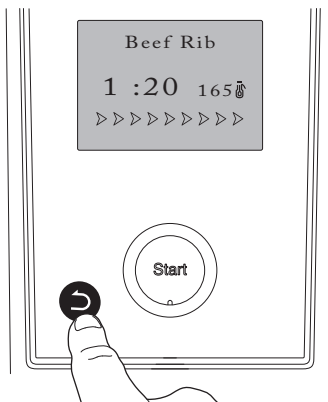

After pressing the **Start** button the orange cooking screen will be shown.

After the cooking program has finished you will hear a several beeps and the pressure cooker will automatically go into the standby mode.

# Sous Vide Function



**Important:** The Sous Vide program does not use steam pressure to cook the ingredients so the pressure release valve **must be set in the open position.**

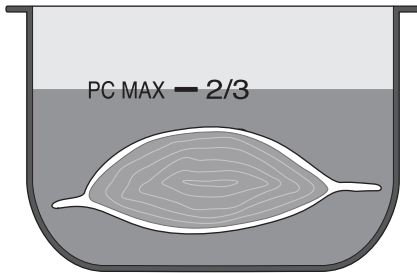

Sous vide is when food is placed in a vacuum sealed bag and cooked at a low temperature for a long time.

Place the bag into the inner pot of the pressure cooker and then fill up with cold water to the MAX 2/3 line on the pot.

Place the pot into the pressure cooker.

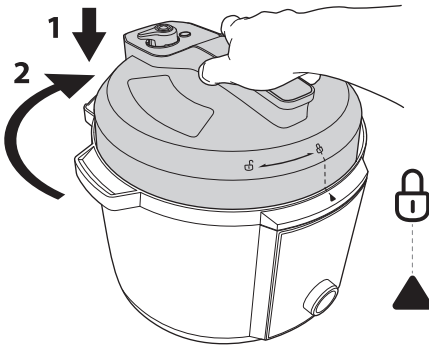

Refit the pressure cookers lid and lock it by turning it anti clockwise.



Ensure the pressure release valve is in the  position.

Plug your pressure cooker in and turn the power on at the socket if required.

## Sous Vide Function (cont...)



Select the **Sous Vide** program by rotating the control knob then press the **Start** button.

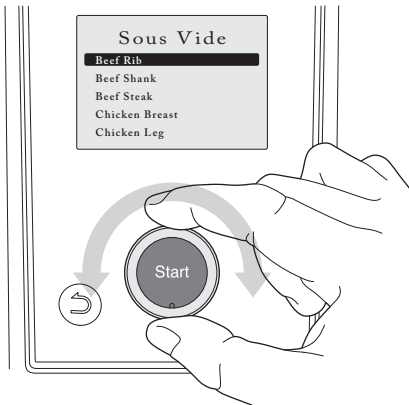

Select the appropriate cooking program by rotating the control knob and then press the **Start** button to open the cooking program.

**Note:** The list of the available cooking programs is shown on page 44.

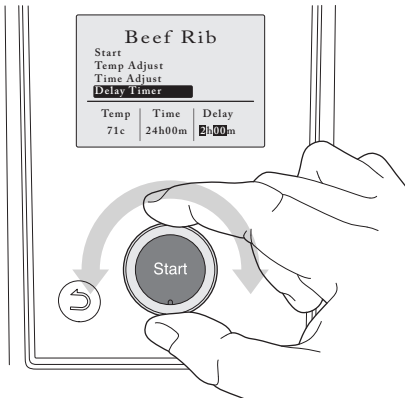

You can now adjust the temperature, cooking time or delay timer of the program if you want to using the control knob as shown on page 19 and 20.

# Sous Vide Program List

Program	Cooking time	Time adjust range	Temperature	Temp adjust range	Delay time range	Keep warm default	Lid ON/OFF
Beef rib	24 hrs	1 to 24 hrs	71°C	30 to 95°C	0 mins to 24 hrs	N/A	ON
Beef shank	24 hrs	1 to 24 hrs	71°C	30 to 95°C	0 mins to 24 hrs	N/A	ON
Beef steak	2 hrs	1 to 24 hrs	57°C	30 to 95°C	0 mins to 24 hrs	N/A	ON
Chicken breast	2 hrs	1 to 24 hrs	62°C	30 to 95°C	0 mins to 24 hrs	N/A	ON
Chicken leg	3 hrs	1 to 24 hrs	65°C	30 to 95°C	0 mins to 24 hrs	N/A	ON
Chicken thigh	3 hrs	1 to 24 hrs	65°C	30 to 95°C	0 mins to 24 hrs	N/A	ON
Fish	30 mins	1 to 24 hrs	55°C	30 to 95°C	0 mins to 24 hrs	N/A	ON
Lamb chop	2 hrs	1 to 24 hrs	60°C	30 to 95°C	0 mins to 24 hrs	N/A	ON
Lamb shank	16 hrs	1 to 24 hrs	66°C	30 to 95°C	0 mins to 24 hrs	N/A	ON
Pork loin	2 hrs	1 to 24 hrs	60°C	30 to 95°C	0 mins to 24 hrs	N/A	ON
Pork chop	2 hrs	1 to 24 hrs	60°C	30 to 95°C	0 mins to 24 hrs	N/A	ON
Pork joint	12 hrs	1 to 24 hrs	75°C	30 to 95°C	0 mins to 24 hrs	N/A	ON
Pork ribs	12 hrs	1 to 24 hrs	75°C	30 to 95°C	0 mins to 24 hrs	N/A	ON
Veg asparagus	15 mins	1 to 24 hrs	85°C	30 to 95°C	0 mins to 24 hrs	N/A	ON
Veg new potato	60 mins	1 to 24 hrs	87°C	30 to 95°C	0 mins to 24 hrs	N/A	ON
Veg potato	80 mins	1 to 24 hrs	84°C	30 to 95°C	0 mins to 24 hrs	N/A	ON
Veg corn cob	60 mins	1 to 24 hrs	84°C	30 to 95°C	0 mins to 24 hrs	N/A	ON

## Sous Vide Function (cont...)

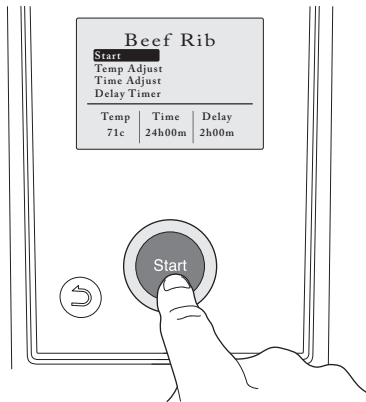

Select **Start** from the menu by rotating the control knob.

Press the **Start** button to begin the cooking process.

**Important:** You can press the ↶ (back) button on the front of the pressure cooker to cancel settings if they are entered wrong.

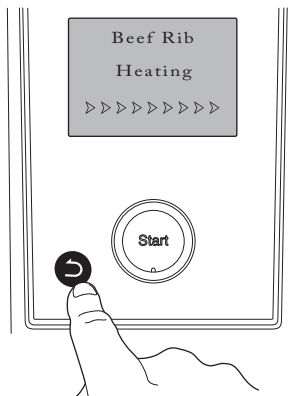

After pressing the **Start** button the yellow cooking screen will show that the pressure cooker is in the heating mode.

**Important:** You can press the ↶ (back) button on the front of the pressure cooker to cancel the cooking process.

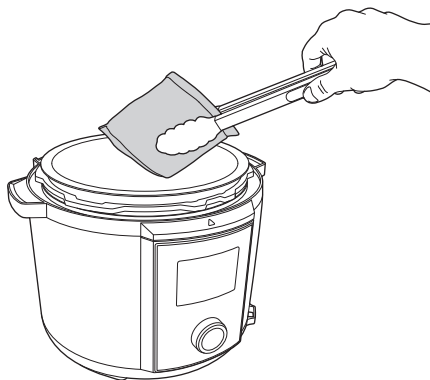

Once the pressure cooker has reached the required temperature the cooking countdown will start.

Once the countdown has finished, the pressure cooker will beep.

Allow the pressure cooker to cool for a few minutes then remove the lid.

Remove the package with a pair of tongs.

# DIY Function



**Important:** The DIY program does not use steam pressure to cook the ingredients so the steam pressure release valve **must be set in the open position.**

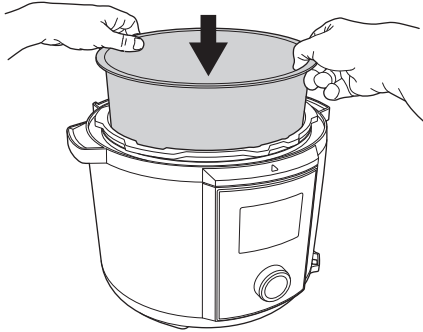

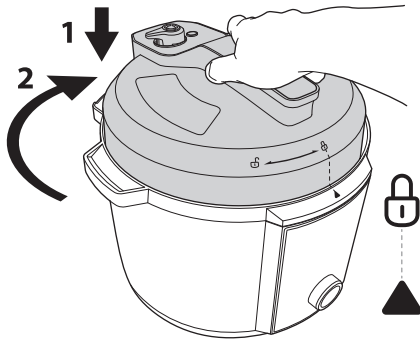

Place all of your prepared ingredients into the inner pot with enough liquid to at least come up to the 1/2 (minimum mark) on the side of the pot.

Place the pot into the pressure cooker.

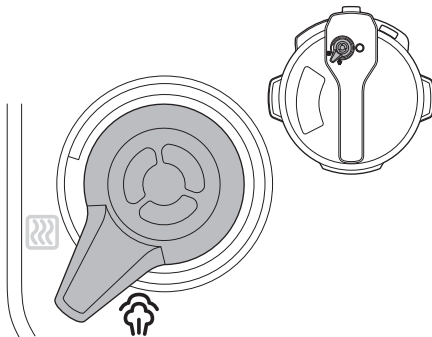

Refit the pressure cookers lid and lock it by turning it anti clockwise as far as it will go.



Ensure the pressure release valve is in the  position.

Plug your pressure cooker in and turn the power on at the socket if required.

## DIY Function (cont...)

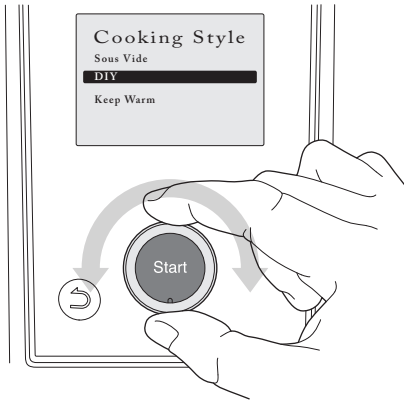

Select **DIY** from the menu by rotating the control knob then press the **Start** button.

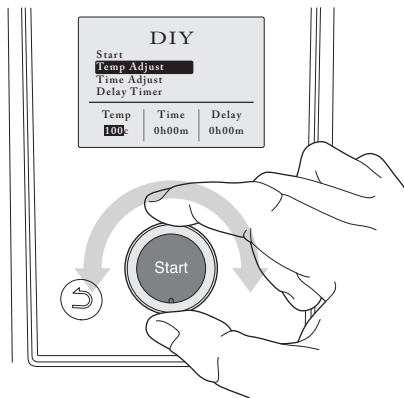

### Setting the temperature

Select **Temp Adjust** by rotating the control knob then press the **Start** button.

The **Temp** section at the bottom of the screen will be highlighted. Rotate the control knob to adjust the temperature and press the **Start** button to set the new temperature.

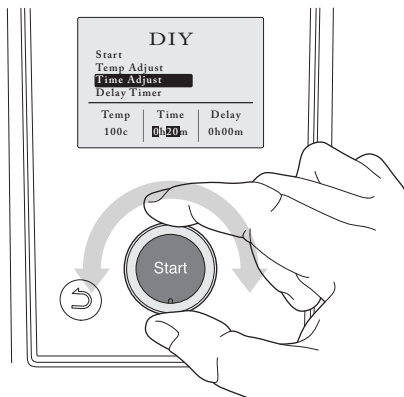

### Setting the time

Select **Time Adjust** by rotating the control knob then press the **Start** button.

The **Time** section at the bottom of the screen will be highlighted. Rotate the control knob to adjust the temperature and press the **Start** button to set the new temperature.

## DIY Function (cont...)

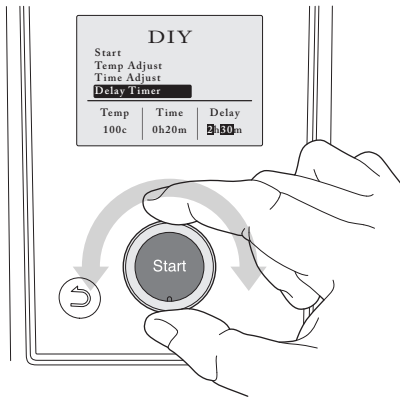

### Setting the delay time

Use the control knob to select the **Delay Timer** setting and press the **Start** button to access.

Use the control knob to adjust the delay timer in 30 minute intervals to a maximum of 24 hours.

When you have the desired time press the **Start** button to confirm.

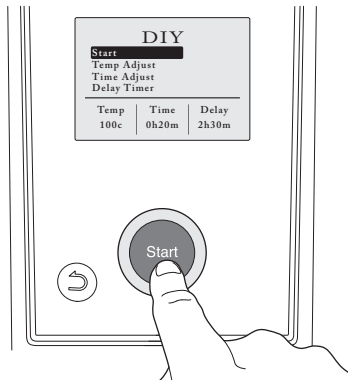

When you have made all of the changes to the cooking program, scroll up to the **Start** setting using the control knob.

Press the **Start** button to start the cooking process.

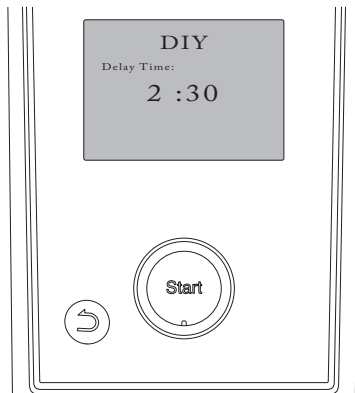

### Using timer delay

If you have used the delay timer, the screen will show the delay timer countdown. After the timer has counted down the cooking process will begin.



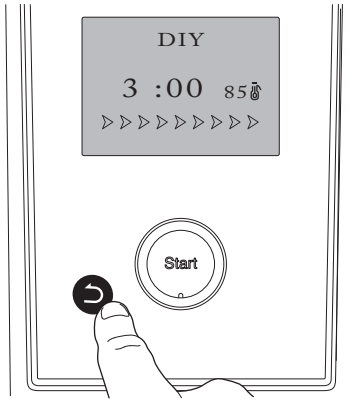

## No timer delay

If you have not used the delay timer, yellow cooking screen will be shown and the pressure cooker will start the cooking process and the countdown will start.

**Important:** You can press the ↶ (back) button on the front of the pressure cooker to cancel the cooking process.

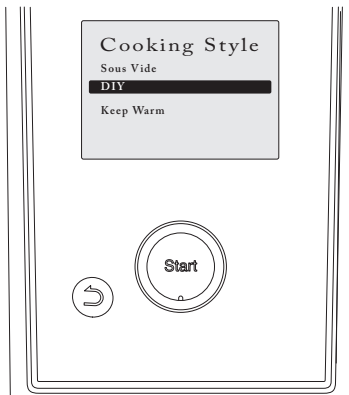

The pressure cooker will beep when the cooking process has finished and automatically go into the standby function.

# Keep Warm Function

**Note:** Use the keep warm function to keep food at an edible temperature for 24 hours.

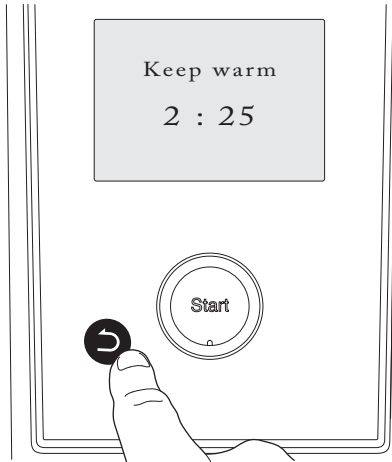

You **MUST** turn the pressure release valve to the open  position as indicated on the valve.

Select **Keep Warm** from the menu by rotating the control knob.

Press the **Start** button to activate the keep warm function.

Press the  (back) button on the front of the pressure cooker to exit the keep warm function.

## Useful Tips

- To cancel any function simply press the  (**Back**) button on the front of the pressure cooker. If the function you were using was a pressurised function, make sure to release the pressure before removing the lid – please see page 27 and 28 on further instructions on how to release the pressure.
- When cooking fish or vegetables, to speed up the cooking time add hot water to the inner pot. **CAUTION: HOT WATER CAN SCALD.**
- If the lid is hard to replace after use, either allow the lid, inner pot & outer case cool down to room temperature or hold in place and push down for a few seconds with the pressure release valve open. This will release any pressure and the lid be easier to close.
- All food can be cooked from frozen, but adjust the time accordingly.
- **WARNING: ALWAYS SHAKE THE CONTENTS OF THE PRESSURE COOKER A FEW TIMES BEFORE OPENING THE LID TO RELEASE ANY TRAPPED STEAM.**
- **TO AVOID THE RISK OF SCALDING, OPEN THE LID VERY SLIGHTLY TO ALLOW STEAM TO ESCAPE GENTLY.**
- **NEVER FORCE THE LID OPEN.**

# Care & Cleaning



**Important:** After every time you use your pressure cooker you must clean any residue food or moisture from all components.

To pressure clean your Clever Chef Pro, please follow the instructions on page 17 and 18. For other cleaning, please look at the instructions below.

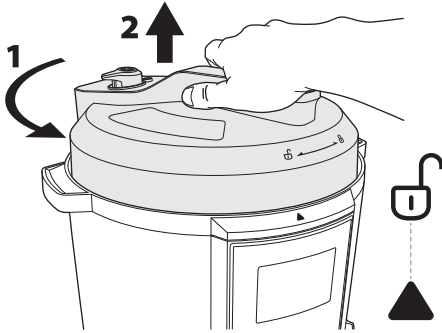

**Removing the lid:** Before cleaning your pressure cooker, you will have to remove the lid.

Rotate the lid anti-clockwise as far as it will go (1).

Lift the lid upwards and off the pressure cooker (2).

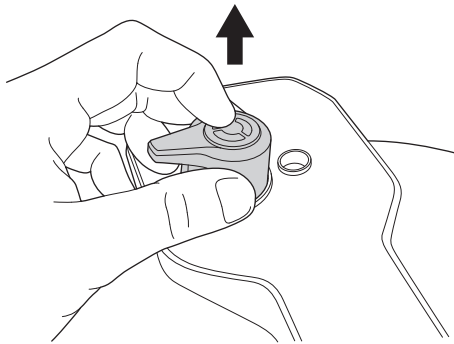

**Removing the pressure release valve:** Grip the sides of the pressure release valve and pull upwards until it comes off the lid. Use a pin to remove any blockages in the valve.

Always ensure there is no pressure in the cooker before removing.

Replace by pushing back into the recess.

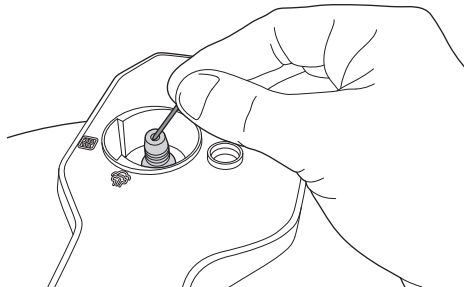

Use a pin to remove any blockages inside or around the valve.

Replace pressure release valve by pushing back into the recess.

Pushdown until it locks in place.

## Care & Cleaning (cont...)

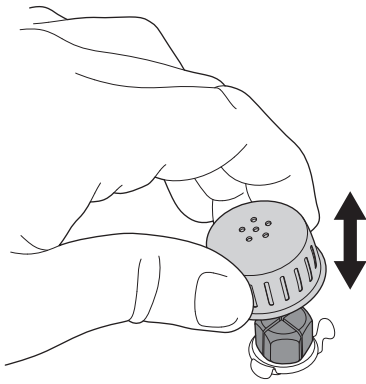

**Cleaning the thimble cover and valve:** The thimble cover is on the inside of the lid and is only visible when the inner lid is removed.

Pull the thimble cover off the valve. Use a pin or brush to remove any blockages inside or around the valve and thimble cover.

Replace thimble cover by pushing back over the valve.

Pushdown until it locks in place.

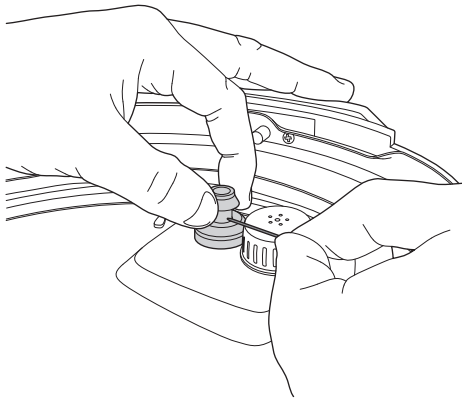

**Cleaning the pressure valve:** Clean the pressure valve using a pin to ensure there is no debris trapped inside or around it.

Check the valve can be raised and will drop back down without sticking.

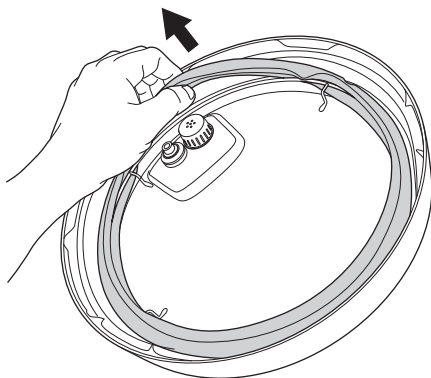

**Removing the gasket:** Pull the rubber gasket from the sides of the inner lid.

Wash the gasket in warm soapy water.

Refit the gasket around the raised ring on the inside of the lid.

## Care & Cleaning (cont...)

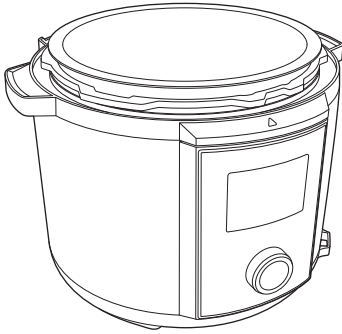

**Cleaning the pressure cooker case:**  
**Never immerse the outer case in water or any liquid.**

Wipe the outer case with a damp cloth then dry thoroughly with a soft dry cloth. Never use abrasive cleaning agents.

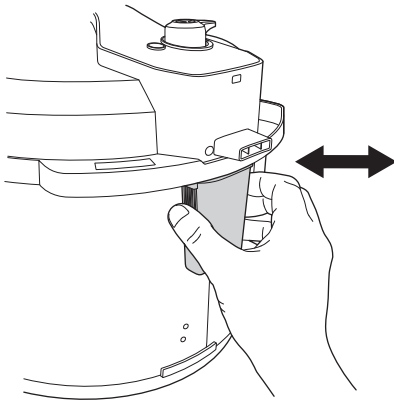

**Condensation cup:** On the back of the steamer you will find the condensation cup.

Pull the condensation cup outwards off the mounting under the hinge.

Wash the cup out with warm soapy water then dry with a soft cloth.

Slot the condensation cup back onto the underside of the hinge.

## Care & Cleaning (cont...)

- Check the gasket periodically to make sure it is clean and flexible, if it is hard and inflexible, you need a replacement. Depending on what you have cooked, you may notice a discolouration of the gasket, this is normal. If you have cooked anything with a strong flavour, we recommend leaving the gasket to soak overnight. **DO NOT** put the gasket in the dishwasher as the heat could warp it and prevent your Clever Chef Pro from working correctly.
- Ensure that the pressure valve on the lid of the pressure cooker is not blocked and can move up and down freely, wipe clean if necessary.
- The inner pot and lid are fully immersible in water for cleaning. Rinse the inner pot and lid under hot running water, using only a mild detergent and a soft cloth or sponge.
- Do not use abrasive powders, bicarbonate of soda or bleach. Never use scouring pads.
- Wipe the base unit with a soft damp cloth, making sure oily food residue is removed.
- **DO NOT IMMERSE THE BASE IN WATER OR ANY OTHER LIQUID.**

## Troubleshooting

Lid does not close properly.	Check that the lid and gasket seal are correctly positioned.
Lid is difficult to remove.	The pressure valve has not dropped. Ensure the pressure has dropped to normal. <b>NEVER FORCE THE LID OPEN.</b>
Steam is released under the lid during cooking.	Ensure the gasket seal is fitted correctly and not worn out. Ensure all food residue is removed from the gasket.
The pressure valve does not rise.	There is not enough food or liquid in the inner pot.
Display shows C1, C2 or C6.	<b>This is a system error</b> - Unplug and allow your pressure cooker to cool down if applicable then close the lid. If the problem persists after plugging your pressure cooker back in, the appliance has developed a fault and needs replacing. Please call Customer Services on: <b>0344 800 0631</b> (UK) / <b>0412 132 998</b> (Ireland) for further advice or email us at: <a href="mailto:customercare@highstreettv.com">customercare@highstreettv.com</a>

## Spare Parts

If you require any more information, assistance or spare parts, please contact our Customer Services Team on:

0344 800 0631 (UK)

0412 132 998 (Ireland)

The current spare parts available for this product are as follows:

- Inner pot
- Condensation cup
- Instruction manual
- Pressure valve
- Trivet
- Steam basket
- Gasket
- Pressure valve and gasket

## Specification

Power supply	220 ~ 240 V <sup>~</sup> 50 Hz
Power	1000 W
Working pressure	80kPa
Maximum allowable pressure	400Kpa

The product and its packaging have been manufactured from valuable materials that can be recycled. Recycling reduces the amount of refuse and helps to preserve the environment.

Dispose of the packaging at a recycling point that sorts materials by type. Make use of the local facilities provided for collecting paper, cardboard and light weight packaging.



Appliances marked with this symbol must not be disposed of along with normal household waste!

You are legally obliged to dispose of old appliances separately from household waste.

Information about collection points where old appliances can be disposed of free of charge is available from your local authorities.

# drew & cole<sup>®</sup>

SWITCHED ON LIVING

Register your product at  
**[drewandcole.com/support](http://drewandcole.com/support)**  
and visit us for...

FAQs Videos Recipes Support



Join our community...



Search: 'Drew and Cole'

Distributed by:  
High Street TV, PO Box 7903,  
Corby, NN17 9HY

Model numbers:  
4.8L – MY-CS5030WP  
5.7L – MY-CS6030WP

V1 09/20

Please recycle our product and  
packaging where facilities exist.  
Check with your Local Authority  
or retailer for recycling in your  
country.

